

Data sheet

Solenoid valve

Types EV220B 15-50 and EV220BW 40-50



EV220B 15-50 and EV220BW 40-50 are a universal indirect servo-operated 2/2-way solenoid valve program.

Valve body in brass, dezincification resistant brass and stainless steel ensures that a broad variety of application can be covered.

Built-in pilot filter as standard, adjustable closing time and enclosures up to IP67 ensures optimal performance even under critical working conditions.

Features and versions:

- For water, steam, oil, compressed air and gases
- Flow range for water: 1.3 – 160 m³/h
- Differential pressure: 0.3 – 16 bar
- Media temperature from -30 – 140 °C
- Ambient temperature: Up to 80 °C
- Coil enclosure: Up to IP67
- Thread connections: From G ½ – G 2
- DN 15 – 50
- Viscosity: Up to 50 cSt
- Water hammer damped
- Built in filter for protection of pilot system
- Adjustable closing time available
- EV220B 15-50 NC and NO brass version for neutral liquids and gasses
- EV220B 15-50 NC DZR brass version for neutral and slightly aggressive liquids and gases
- EV220B 15-50 NC Stainless Steel version for neutral and aggressive liquids and gases
- EV220BW 40-50 NC+NO EPDM and WRAS for drinking water

EV220B 15-50
Brass valve body, NC



- WRAS (see table below)
- ACS
- PZH
- In accordance with:
 - Low Voltage Directive 2014/35/EU
 - EN60730-1
 - EN60730-2-8
 - Pressure Equipment Directive 2014/68/EU
- UL recognized

Connection ISO228/1	Seal material	Orifice size	K _v - value	Differential pressure min. to max. ⁶⁾	Max. working pressure	Media temperature min. to max.	Approval	Code number
			[m ³ /h]	[bar]	[bar]	[°C]		
G ½	EPDM ¹⁾	15	4	0.3 – 16	16	-30 – 120 ⁴⁾		032U7115
	NBR ²⁾	15	4	0.3 – 16	16	-10 – 90		032U7170
	FKM ³⁾	15	4	0.3 – 10	10	0 – 100 ⁵⁾		032U7116
G ¾	EPDM ¹⁾	20	8	0.3 – 16	16	-30 – 120 ⁴⁾		032U7120
	NBR ²⁾	20	7.5	0.3 – 16	16	-10 – 90		032U7171
	FKM ³⁾	20	8	0.3 – 10	10	0 – 100 ⁵⁾		032U7121
G 1	EPDM ¹⁾	25	11	0.3 – 16	16	-30 – 120 ⁴⁾		032U7125
	NBR ²⁾	25	11	0.3 – 16	16	-10 – 90		032U7172
	FKM ³⁾	25	11	0.3 – 10	10	0 – 100 ⁵⁾		032U7126
G 1 ¼	EPDM ¹⁾	32	18	0.3 – 12	12	-30 – 120 ⁴⁾		032U7132
	NBR ²⁾	32	18	0.3 – 12	12	-10 – 90		032U7173
	FKM ³⁾	32	18	0.3 – 10	10	0 – 100 ⁵⁾		032U7133
G 1 ½	EPDM ¹⁾	40	24	0.3 – 12	12	-30 – 120 ⁴⁾		032U7140
	NBR ²⁾	40	24	0.3 – 12	12	-10 – 90		032U7174
	FKM ³⁾	40	24	0.3 – 10	10	0 – 100 ⁵⁾		032U7141
G 2	EPDM ¹⁾	50	40	0.3 – 12	12	-30 – 120 ⁴⁾		032U7150
	NBR ²⁾	50	40	0.3 – 12	12	-10 – 90		032U7175
	FKM ³⁾	50	40	0.3 – 10	10	0 – 100 ⁵⁾		032U7151

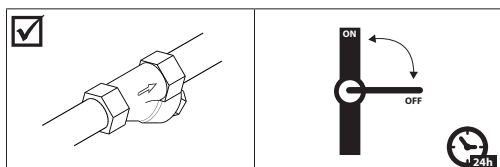

- ¹⁾ EPDM is recommended for water.
²⁾ NBR is suitable for oil, water and air.
³⁾ FKM is suitable for oil and air. For water at max. +60 °C.
⁴⁾ Low pressure steam, 4 bar: Max. 140 °C.
 BA AC/DC and BB/BE DC coils: Max. 100 °C.
 BO and BP coils: Max. 90 °C.
⁵⁾ For water: Max. 60 °C.
 BO and BP coils: Max. 90 °C.
⁶⁾ It is recommended to use a filter in front of the valve.
⁷⁾ In water applications, exercise the valves at least once every 24 hours, meaning change the state of the valve.
 The valve exercise will minimize the risk of the valve sticking due to calcium carbonate, zinc or iron oxide build-up.



**EV220BW 40-50
with sealings for
drinking water
Brass valve body, NC**



- WRAS 
- In accordance with:
 - Low Voltage Directive 2014/35/EU
 - EN60730-1
 - EN60730-2-8
 - Pressure Equipment Directive 2014/68/EU

Connection ISO228/1	Seal material	Orifice size	K _v - value	Differential pressure min. to max. ¹⁾	Max. working pressure	Media temperature min. to max.	Approval	Code number
			[m ³ /h]	[bar]	[bar]	[°C]		
G 1 ½	EPDM	40	24	0.3 – 10	10	0 – 90		132U4003
G 2	EPDM	50	40	0.3 – 10	10	0 – 90		132U5003

¹⁾ It is recommended to use a filter in front of the valve.
²⁾ In water applications, exercise the valves at least once every 24 hours, meaning change the state of the valve.
 The valve exercise will minimize the risk of the valve sticking due to calcium carbonate, zinc or iron oxide build-up.

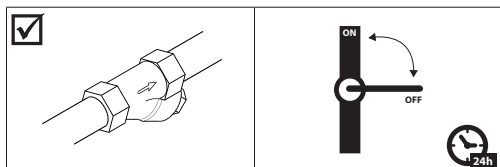

EV220B 15-50
Brass valve body, NO



- WRAS (see table below)
- ACS
- PZH
- In accordance with:
 - Low Voltage Directive 2014/35/EU
 - EN60730-1
 - EN60730-2-8
 - Pressure Equipment Directive 2014/68/EU
- UL recognized

Connection ISO228/1	Seal material	Orifice size	K _v - value	Differential pressure min. to max.	Max. working pressure	Media temperature min. to max.	Approval	Code no.
			[m ³ /h]	[bar] ⁶⁾	[bar]	[°C]		
G ½	EPDM ¹⁾	15	4	0.3 – 10	10	-30 – 120 ⁴⁾		032U7117
	NBR ²⁾	15	4	0.3 – 10	10	-10 – 90		032U7180
	FKM ³⁾	15	4	0.3 – 10	10	0 – 100 ⁵⁾		032U7118
G ¾	EPDM ¹⁾	20	8	0.3 – 10	10	-30 – 120 ⁴⁾		032U7122
	NBR ²⁾	20	7.5	0.3 – 10	10	-10 – 90		032U7181
	FKM ³⁾	20	8	0.3 – 10	10	0 – 100 ⁵⁾		032U7123
G 1	EPDM ¹⁾	25	11	0.3 – 10	10	-30 – 120 ⁴⁾		032U7127
	NBR ²⁾	25	11	0.3 – 10	10	-10 – 90		032U7182
	FKM ³⁾	25	11	0.3 – 10	10	0 – 100 ⁵⁾		032U7128
G 1 ¼	EPDM ¹⁾	32	18	0.3 – 10	10	-30 – 120 ⁴⁾		032U7134
	NBR ²⁾	32	18	0.3 – 10	10	-10 – 90		032U7183
	FKM ³⁾	32	18	0.3 – 10	10	0 – 100 ⁵⁾		032U7135
G 1 ½	EPDM ¹⁾	40	24	0.3 – 10	10	-30 – 120 ⁴⁾		032U7142
	NBR ²⁾	40	24	0.3 – 10	10	-10 – 90		032U7184
	FKM ³⁾	40	24	0.3 – 10	10	0 – 100 ⁵⁾		032U7143
G 2	EPDM ¹⁾	50	40	0.3 – 10	10	-30 – 120 ⁴⁾		032U7152
	NBR ²⁾	50	40	0.3 – 10	10	-10 – 90		032U7185
	FKM ³⁾	50	40	0.3 – 10	10	0 – 100 ⁵⁾		032U7153

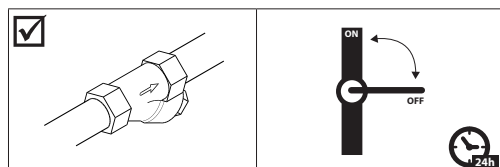

- ¹⁾ EPDM is recommended for water.
²⁾ NBR is suitable for oil, water and air.
³⁾ FKM is suitable for oil and air. For water at max. 60 °C.
⁴⁾ Low pressure steam, 4 bar: Max. 140 °C.
 BA AC/DC and BB/BE DC coils: Max. 100 °C.
 BO and BP coils: Max. 90 °C.
⁵⁾ For water: Max. 60 °C.
 BO and BP coils: Max. 90 °C.
⁶⁾ It is recommended to use a filter in front of the valve.
⁷⁾ In water applications, exercise the valves at least once every 24 hours, meaning change the state of the valve.
 The valve exercise will minimize the risk of the valve sticking due to calcium carbonate, zinc or iron oxide build-up.



EV220BW 40-50
with sealings for
drinking water
Brass valve body, NO



- WRAS 
- In accordance with:
 - Low Voltage Directive 2014/35/EU
 - EN60730-1
 - EN60730-2-8
 - Pressure Equipment Directive 2014/68/EU

Connection ISO228/1	Seal material	Orifice size	K _v - value	Differential pressure min. to max.	Max. working pressure	Media temperature min. to max.	Approval	Code no.
			[m ³ /h]	[bar] ⁶⁾	[bar]	[°C]		
G 1 ½	EPDM	40	24	0.3 – 10	10	0 – 90	 Pending	132U4004
G 2	EPDM	50	40	0.3 – 10	10	0 – 90	 Pending	132U5004

¹⁾ It is recommended to use a filter in front of the valve.

²⁾ In water applications, exercise the valves at least once every 24 hours, meaning change the state of the valve.
 The valve exercise will minimize the risk of the valve sticking due to calcium carbonate, zinc or iron oxide build-up.

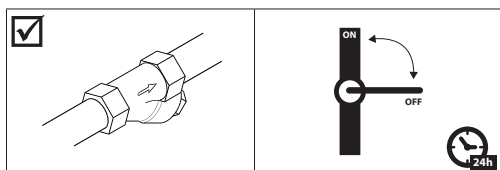

Data sheet | Solenoid valves, type EV220B 15-50 and EV220BW 40-50

Technical data, brass valve body, NC and NO

Main type	EV220B 15B	EV220B 20B	EV220B 25B	EV220B 32B	EV220B 40B	EV220B 50B
Time to open [ms] ¹⁾	40	40	300	1000	1500	5000
Time to close [ms] ¹⁾	350	1000	1000	2500	4000	10000

¹⁾ The times are indicative and apply to water. The exact times will depend on the pressure conditions.
Closing times can be changed by replacement of the equalizing orifice.

Installation	Optional, but vertical solenoid system is recommended		
Max. test pressure	20 bar		
Viscosity	Max. 50 cSt		
Materials	Valve body:	Brass	W.no. 2.0402
	Armature:	Stainless steel	W.no. 1.4105 / AISI 430 FR
	Armature tube:	Stainless steel	W.no. 1.4306 / AISI 304 L
	Armature stop:	Stainless steel	W.no. 1.4105 / AISI 430 FR
	Springs	Stainless steel	W.no. 1.4310 / AISI 301
	O-rings:	EPDM, FKM or NBR	
	Valve plate:	EPDM, FKM or NBR	
	Diaphragm:	EPDM, FKM or NBR	

EV220B 15-50
Dezincification resistant
brass (DZR)
Valve body, NC



- WRAS
- ACS
- PZH
- In accordance with:
 - Low Voltage Directive 2014/35/EU
 - EN60730-1
 - EN60730-2-8
 - Pressure Equipment Directive 2014/68/EU
- UL recognized

Connection ISO228/1	Seal material	Orifice size	K _v -value	Differential pressure Min. – max.	Max. working pressure	Media temperature min. to max.	Approval	Code no.
			[m ³ /h]	[bar]	[bar]	[°C]		
G ½	EPDM ¹⁾	15	4	0.3 – 16	16	-30 – 120 ²⁾		032U5815
G ¾	EPDM ¹⁾	20	8	0.3 – 16	16	-30 – 120 ²⁾		032U5820
G 1	EPDM ¹⁾	25	11	0.3 – 16	16	-30 – 120 ²⁾		032U5825
G 1 ¼	EPDM ¹⁾	32	18	0.3 – 12	12	-30 – 120 ²⁾		032U5832
G 1 ½	EPDM ¹⁾	40	24	0.3 – 12	12	-30 – 120 ²⁾		032U5840
G 2	EPDM ¹⁾	50	40	0.3 – 12	12	-30 – 120 ²⁾		032U5850

¹⁾ EPDM is recommended for water.
²⁾ Low pressure steam, 4 bar: Max. 140 °C.
 BA AC/DC and BB/BE DC coils: Max. 100 °C.
 BO and BP coils: Max. 90 °C.
⁶⁾ It is recommended to use a filter in front of the valve.
⁷⁾ In water applications, exercise the valves at least once every 24 hours, meaning change the state of the valve.
 The valve exercise will minimize the risk of the valve sticking due to calcium carbonate, zinc or iron oxide build-up.

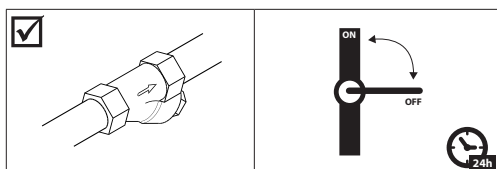

Technical data

Main type	EV220B 15BD	EV220B 20BD	EV220B 25BD	EV220B 32BD	EV220B 40BD	EV220B 50BD
Time to open [ms] ¹⁾	40	40	300	1000	1500	5000
Time to close [ms] ¹⁾	350	1000	1000	2500	4000	10000

¹⁾ The times are indicative and apply to water. The exact times will depend on the pressure conditions.
 Closing times can be changed by replacement of the equalizing orifice.

Installation	Optional, but vertical solenoid system is recommended.		
Max. test pressure	20 bar		
Viscosity	Max. 50 cSt		
Materials	Valve body:	Dezincification resistant brass (DZR)	CuZn36Pb2As / CZ132
	Armature:	Stainless steel	W.no. 1.4105 / AISI 430 FR
	Armature tube:	Stainless steel	W.no. 1.4306 / AISI 304 L
	Armature stop:	Stainless steel	W.no. 1.4105 / AISI 430 FR
	Springs	Stainless steel	W.no. 1.4310 / AISI 301
	Orifices	Stainless steel	W.no. 1.4404 / AISI 316L
	Valve seat	Stainless steel	W.no. 1.4404 / AISI 316L
	O-rings	EPDM	
	Valve plate	EPDM	
Diaphragm	EPDM		

EV220B 15-50
Stainless steel valve body, NC



- PZH
- In accordance with:
 - Low Voltage Directive 2014/35/EU
 - EN60730-1
 - EN60730-2-8
 - Pressure Equipment Directive 2014/68/EU
- UL recognized

Connection ISO228/1	Seal material	Orifice size	K _v - value	Differential pressure min. – max.	Max. working pressure	Media temperature min. to max.	Code no.
			[m ³ /h]	[bar]	[bar]	[°C]	
G ½	EPDM ¹⁾	15	4	0.3 – 16	16	-30 – 120 ²⁾	032U8500
	FKM ²⁾	15	4	0.3 – 10	10	-30 – 120 ²⁾	032U8506
G ¾	EPDM ¹⁾	20	8	0.3 – 16	16	-30 – 120 ²⁾	032U8501
	FKM ²⁾	20	8	0.3 – 10	10	-30 – 120 ²⁾	032U8507
G 1	EPDM ¹⁾	25	11	0.3 – 16	16	-30 – 120 ²⁾	032U8502
	FKM ²⁾	25	11	0.3 – 10	10	-30 – 120 ²⁾	032U8508
G 1 ¼	EPDM ¹⁾	32	18	0.3 – 12	12	-30 – 120 ²⁾	032U8503
	FKM ²⁾	32	18	0.3 – 10	10	-30 – 120 ²⁾	032U8509
G 1 ½	EPDM ¹⁾	40	24	0.3 – 12	12	-30 – 120 ²⁾	032U8504
	FKM ²⁾	40	24	0.3 – 10	10	-30 – 120 ²⁾	032U8510
G 2	EPDM ¹⁾	50	40	0.3 – 12	12	-30 – 120 ²⁾	032U8505
	FKM ²⁾	50	40	0.3 – 10	10	-30 – 120 ²⁾	032U8511

- ¹⁾ EPDM is recommended for water. (steam max. +140 °C / 4 bar).
- ²⁾ FKM is suitable for oil and air. For water at max. +60 °C.
- ³⁾ Low pressure steam, 4 bar: Max. +140 °C.
BA AC/DC and BB/BE DC coils: Max. +100 °C.
BO and BP coils: Max. +90 °C.
- ⁴⁾ For water: Max. +60 °C.
BO and BP coils: Max. +90 °C.
- ⁵⁾ It is recommended to use a filter in front of the valve.
- ⁷⁾ In water applications, exercise the valves at least once every 24 hours, meaning change the state of the valve.
The valve exercise will minimize the risk of the valve sticking due to calcium carbonate, zinc or iron oxide build-up.

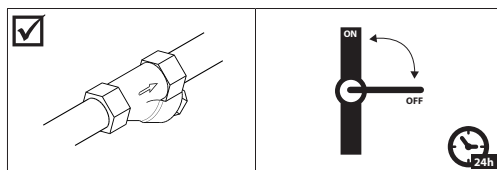

Technical data, stainless steel valve body, NC

Main type	EV220B 15SS	EV220B 20SS	EV220B 25SS	EV220B 32SS	EV220B 40SS	EV220B 50SS
Time to open [ms] ¹⁾	40	40	300	1000	1500	5000
Time to close [ms] ¹⁾	350	1000	1000	2500	4000	10000

- ¹⁾ The times are indicative and apply to water. The exact times will depend on the pressure conditions.
Closing times can be changed by replacement of the equalizing orifice.

Installation	Optional, but vertical solenoid system is recommended.		
Max. test pressure	20 bar		
Viscosity	Max. 50 cSt		
Materials	Valve body:	Stainless steel	W.no. 1.4581 / AISI 318
	Armature:	Stainless steel	W.no. 1.4105 / AISI 430 FR
	Armature tube:	Stainless steel	W.no. 1.4306 / AISI 304 L
	Armature stop:	Stainless steel	W.no. 1.4105 / AISI 430 FR
	Springs:	Stainless steel	W.no. 1.4310 / AISI 301
	Orifices:	Stainless steel	W.no. 1.4404 / AISI316L
	O-rings:	EPDM or FKM	
Valve plate:	EPDM or FKM		
Diaphragm:	EPDM or FKM		

Dimensions and weight:
 Brass, DZR brass and
 stainless steel,
 NC and NO

Type	L	B	B ₁ [mm] / coil type				H	H ₁	Weight without coil [kg]
	[mm]	[mm]	BA	BB / BE	BG / BO	BP	[mm]	[mm]	
EV220B 15	80.0	52.0	32	46	68	45	99	15.0	0.7
EV220B 20	90.0	58.0	32	46	68	45	103	18.0	0.9
EV220B 25	109.0	70.0	32	46	68	45	113	22.0	1.3
EV220B 32	120.0	82.0	32	46	68	45	120	27.0	2.0
EV220B / BW 40	130.0	95.0	32	46	68	45	129	32.0	3.0
EV220B / BW 50	162.0	113.0	32	46	68	45	135	37.0	4.8

Dimensions

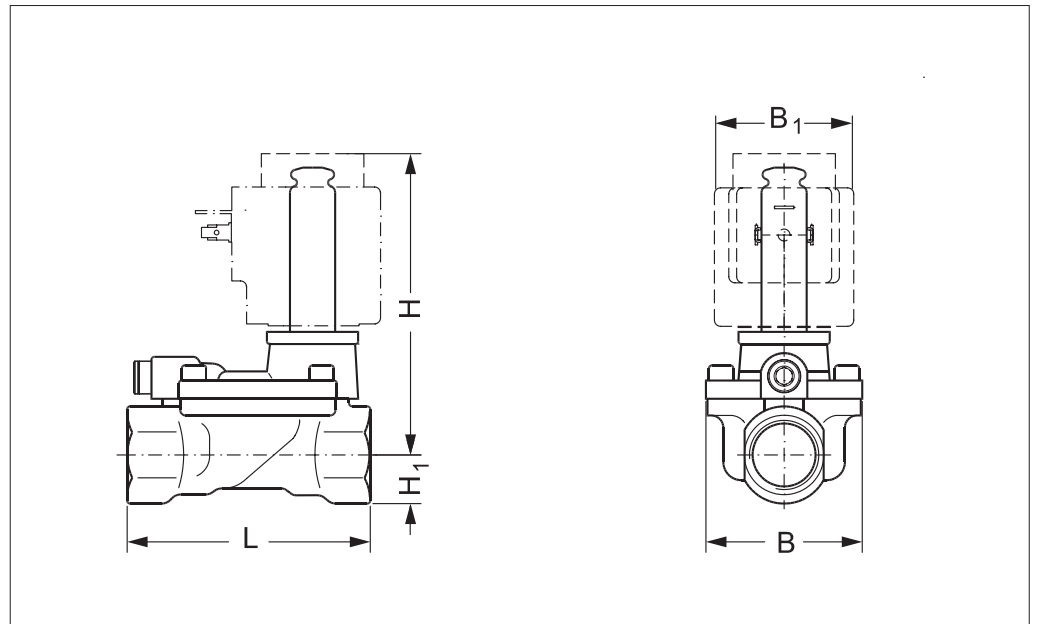

Mounting angle

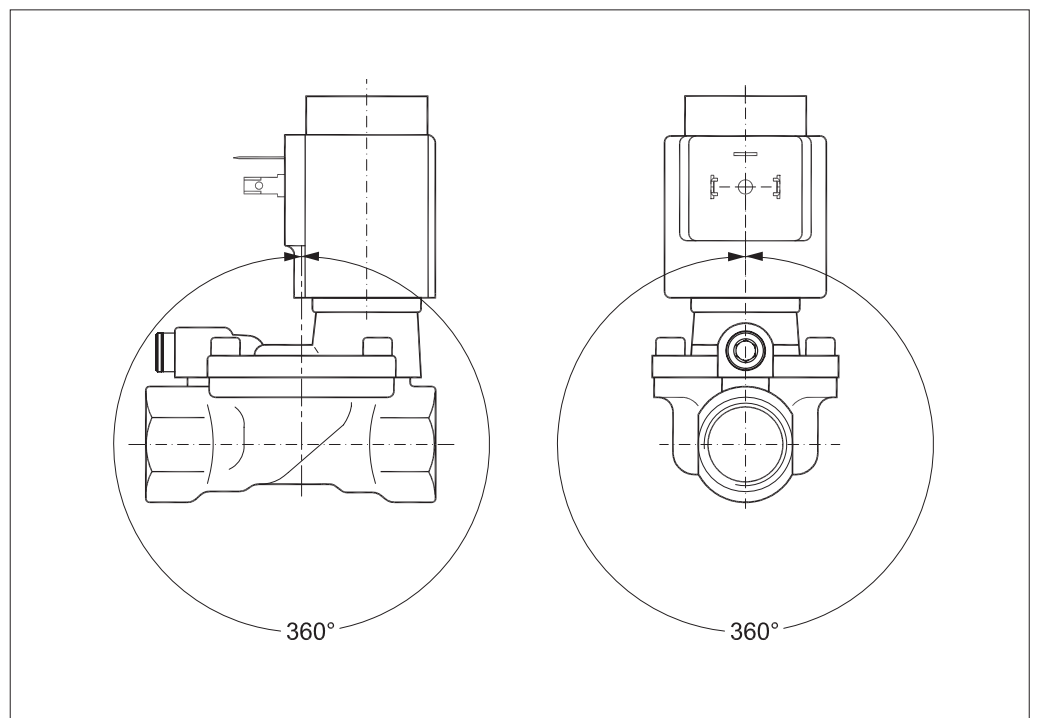

Below coils can be used with EV220B 15 – EV220B 50 – EV220BW 40-50

Coil	Type	Power consumption	Enclosure	Features
	BA / BD, screw on	9 W AC 15 W DC	IP00 with spade connector	IP20 with protective cap, IP65 with cable plug
	BB, clip on	10 W AC 18 W DC	IP00 with spade connector	IP20 with protective cap, IP65 with cable plug
	BE, clip on	10 W AC 18 W DC	IP67	With terminal box
	BF, clip on	10 W AC 18 W DC	IP67	With 1 m cable
	BG, clip on	12 W AC 20 W DC	IP67	With terminal box
	BN, clip on	20 W 26 VA	IP67	Hum free With terminal box and 1 m cable
	BO, screw on	10 W 21 VA	IP67 only including seal kit 018Z0090	For explosion-risk environment zone 1. With terminal box and 5 m cable

For further information and for ordering, see separate data sheet for coils.

Accessories:
Cable plug



Application	Code no.
GDM 2011 (grey) cable plug according to DIN 43650-A PG11	042N0156

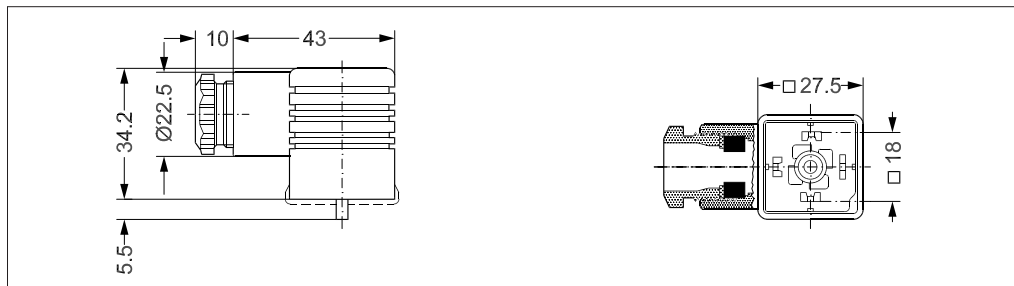

Universal electronic multi-timer, type ETM



Application	Voltage	To use with coil	Ambient temperature	Code no.
	[V AC]		[°C]	
External adjustable timing from 1 to 45 minutes with 1 to 15 seconds drain open. With manual override (test button). Electrical connection DIN 43650 A / EN 175 301-803-A	24 – 240	BA, BD, BB	-10 – 50	042N0185

- Outside adjustments
- Light weight and small size
- External adjustable timing from 1 minute to 45 minutes with 1 to 15 seconds drain open
- One solid state timer fits all coil voltages from 24 – 240 V AC
- Light diodes for indication
- All in one unit
- Manual override (test button)

Technical data

Type	ET 20 M
Voltage	24 – 240 V AC / 50/60 Hz.
Power rating	Max. 20 Watt
Enclosure	IP00, IP65 with power connector (cable plug)
Electrical connection	DIN connector (DIN 43650-A)
Ambient operating temperature range	-10 – 50 °C
Function	Start with pulse
Interval timer	1 – 45 min.
“On” timer	1 – 15 sec.
Weight	0.084 kg

Dimensions

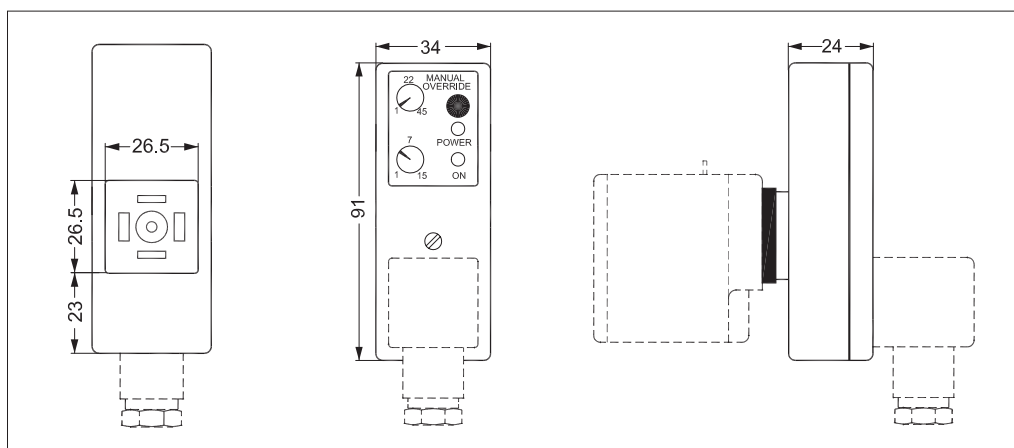

Manual override unit, tool operated

Used for manual override in event of power failure.
Note: Valve height is increased by 16 mm.

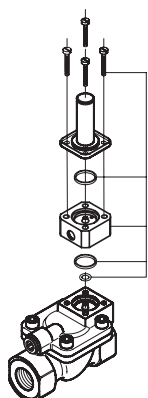

The unit consists of:
 Manual override body
 4 screws
 3 O-rings (seal material NBR)



Size [DN]	Body material	Seal material			Equalizing orifice	Media	Media temperature [°C]	Code no.
		FKM	NBR	EPDM				
15 – 32	Brass	x	x	x	n/a ²⁾	Air, oil, water	-10 – 90	032U0150
	Stainless steel	x	x	x	n/a ²⁾	Air, oil, water	-10 – 90	032U0149
40 – 50	Stainless steel	n/a ¹⁾	n/a ¹⁾	x	n/a ²⁾	Water	-10 – 90	032U0149

¹⁾ Risk of functional failure.
²⁾ Original equalizing orifice to be used.

Manual override unit including equalizing orifice, tool operated

Used for manual override in event of power failure.
Note: Valve height is increased by 16 mm.

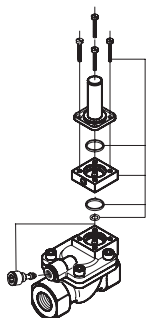

The unit consists of:
 Manual override body
 4 screws
 3 O-rings (seal material NBR)
 Equalizing orifice, size III



Size [DN]	Body material	Seal material			Equalizing orifice	Media	Media temperature [°C]	Code no.
		FKM	NBR	EPDM				
40 – 50	Brass	x	x	x	Size III ³⁾	Water	-10 – 90	032U0260

³⁾ For FKM and NBR valves, it is recommended to change the equalizing orifice to size III, to obtain a proper function.

Manual override unit, hand operated

Used for manual override in event of power failure.

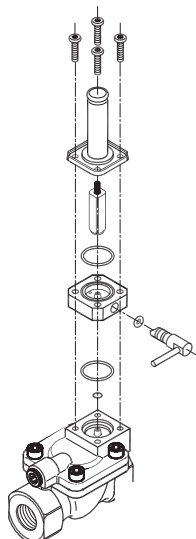

The unit consists of:
 Armature incl. closing spring
 Armature tube
 Stainless steel valve body
 O-ring 3.68 x 1.78
 O-ring 19 x 1.5
 O-ring 5 x 2.5
 4 screws
 4 nuts for transportation purpose only



Size [DN]	Body material	Seal material			Equalizing orifice	Media	Media temperature [°C]	Code no.
		FKM	NBR	EPDM				
15 – 32	Brass	n/a ¹⁾	n/a ¹⁾	x	n/a ²⁾	Water	-30 – 120	032U7390
	Stainless steel	n/a ¹⁾	n/a ¹⁾	x	n/a ²⁾	Water	-30 – 120	
40 – 50	Brass	n/a ¹⁾	n/a ¹⁾	x	n/a ²⁾	Water	-30 – 120	
	Stainless steel	n/a ¹⁾	n/a ¹⁾	x	n/a ²⁾	Water	-30 – 120	

¹⁾ Risk of functional failure.
²⁾ Original equalizing orifice to be used.

Isolating diaphragm kit

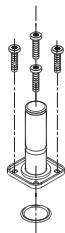

Seal material	Media temperature	Code no.
	[°C]	
EPDM	-20 – 50	042U1009
FKM	0 – 50	042U1010



The isolating diaphragm design ensures that no fluid enters the armature area, which gives the following advantages:

The valve is resistant to aggressive fluids, impurities in the fluid and to calcareous and scale deposits.

The kit contains:

- Assembled isolating unit
- O-ring
- 4 screws
- Locking button
- Nut for the coil

Equalizing orifice



The kit comprises:

An equalizing orifice includes 2 O-rings. The valves closing time can be changed by installing an equalizing orifice of a size which deviates from the standard valve:

- A shorter closing time is obtained with a larger orifice (the shorter closing time, the greater risk of water hammering)
- A longer closing time is obtained with a smaller orifice.

Equalizing orifice size [mm]	Seal material	Applicable in	Code no.	
			Brass	DZR brass ³⁾ / Stainless steel
0.5	EPDM ¹⁾	EV220B 15 EV220B 20	032U0082	032U6310
0.8	EPDM ¹⁾	EV220B 25 EV220B 32 EV220B 40	032U0084	032U6311
1.2	FKM ²⁾	EV220B 25 EV220B 32	032U0085	032U6314
1.2	EPDM ¹⁾	EV220B 50	032U0086	032U6312
1.4	FKM ²⁾	EV220B 40 EV220B 50	032U0087	032U6315

Adjustable orifice



The kit comprises:

An adjustable orifice including O-ring and gasket.

The valves closing time can be adjusted by turning the setting screw.

Orifice	Seal material	Applicable in	Material	Code no.
Adjustable	EPDM ¹⁾	All EV220B 15 – EV220B 50 valves	Brass	032U0682
Adjustable	FKM ²⁾	All EV220B 15 – EV220B 50 valves	Brass	032U0683

¹⁾ Approved by WRAS.
Approved by Attestation de Conformite Sanitaire (ACS).
EPDM is recommended for water. (Steam max. 40 °C / 4 bar).
²⁾ FKM is suitable for oil and air. For water at max. 60 °C.
³⁾ Dezincification resistant brass.

Spare parts kit, NC

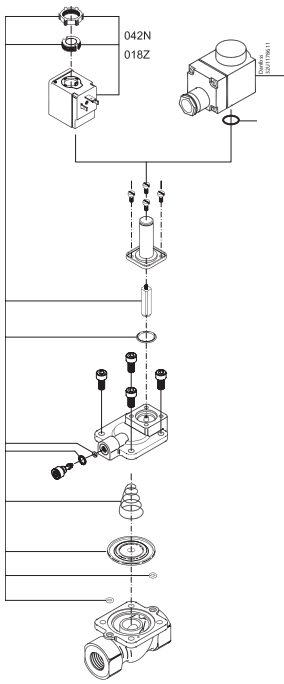

Brass versions		
Type	Seal material	Code no.
EV220B 15	EPDM ¹⁾	032U1071
EV220B 15	FKM ²⁾	032U1072
EV220B 15	NBR ³⁾	032U6013
EV220B 20	EPDM ¹⁾	032U1073
EV220B 20	FKM ²⁾	032U1074
EV220B 20	NBR ³⁾	032U6014
EV220B 25	EPDM ¹⁾	032U1075
EV220B 25	FKM ²⁾	032U1076
EV220B 25	NBR ³⁾	032U6015
EV220B 32	EPDM ¹⁾	032U1077
EV220B 32	FKM ²⁾	032U1078
EV220B 32	NBR ³⁾	032U6016
EV220B 40	EPDM ¹⁾	032U1079
EV220B 40	FKM ²⁾	032U1080
EV220B 40	NBR ³⁾	032U6017
EV220B 50	EPDM ¹⁾	032U1081
EV220B 50	FKM ²⁾	032U1082
EV220B 50	NBR ³⁾	032U6018

DZR brass ⁴⁾ and stainless steel versions		
Type	Seal material	Code no.
EV220B 15	EPDM ¹⁾	032U6320
EV220B 15	FKM ²⁾	032U6326
EV220B 20	EPDM ¹⁾	032U6321
EV220B 20	FKM ²⁾	032U6327
EV220B 25	EPDM ¹⁾	032U6322
EV220B 25	FKM ²⁾	032U6328
EV220B 32	EPDM ¹⁾	032U6323
EV220B 32	FKM ²⁾	032U6329
EV220B 40	EPDM ¹⁾	032U6324
EV220B 40	FKM ²⁾	032U6330
EV220B 50	EPDM ¹⁾	032U6325
EV220B 50	FKM ²⁾	032U6331

- ¹⁾ DN 15-32 approved by WRAS.
DN 15-50 (Brass and DZR) approved by Attestation de Conformite Sanitaire (ACS) and PZH.
DN 15-50 SS approved by PZH.
EPDM is recommended for Water.
(steam max. 140°C/ 4 bar)
- ²⁾ FKM is suitable for oil and air. For water at max. 60 °C.
- ³⁾ NBR is suitable for oil, water and air.
- ⁴⁾ Dezincification resistant brass.

The kit contains:

- Locking button and nut for the coil
- Armature with valve plate and spring
- O-ring for the armature tube
- 2 O-rings for the equalizing orifice
- Spring and diaphragm
- 2 O-rings for the pilot system



Spare parts kits
DN40 and DN50
EPDM WRAS approved

Type	Valve code no.	Actuator kit NC ¹⁾	Actuator kit NO ²⁾	Diaphragm kit NC and NO ³⁾
EV220BW DN 40 NC	132U4003	132U8080		132U8041
EV220BW DN 50 NC	132U5003	132U8080		132U8051
EV220BW DN 40 NO	132U4004		132U8081	132U8041
EV220BW DN 50 NO	132U5004		132U8081	132U8051

- The kits contains
- ¹⁾ and ³⁾ Armature tube, armature with spring, o-ring and 4 screws.
 - ²⁾ No unit, o-ring and 4 screws
 - ⁴⁾ Diaphragm, closing spring, 2 o-rings, equalising orifice + 2 o-rings and screws

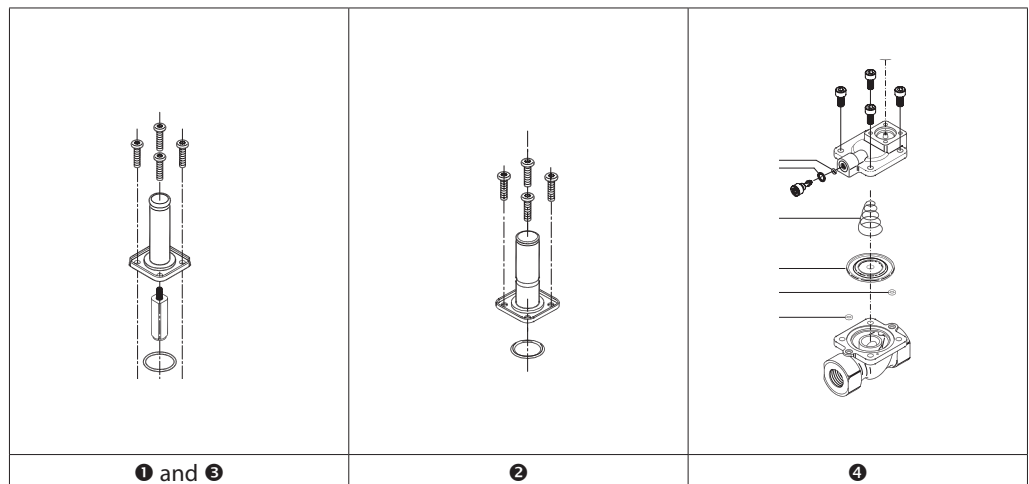

To get a complete acatuator and diaphragm service 1), 2) or 3) and 4) should be ordered.
Fx. For EV220BW 15 / G1/2 NC needed ordering are 132U8080 and 132U8016.

Spare parts kit, NO

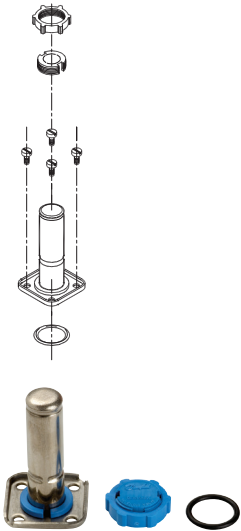

Type	Seal material	Code no.
EV220B 15 EV220B 50	EPDM ¹⁾	032U0296
	FKM ²⁾	032U0295
	NBR ³⁾	032U0299

- ¹⁾ EPDM is recommended for water. (Steam max. 140 °C / 4 bar).
- ²⁾ FKM is suitable for oil and air. For water at max. +60 °C.
- ³⁾ NBR is suitable for oil, water and air.

The kit contains:

- Locking button and nut for the coil
- NO actuator unit
- O-ring for the armature unit

Function
NC, brass, DZR brass and stainless steel

Coil voltage disconnected (closed):

When the voltage is disconnected, the valve plate (3) is pressed down against the pilot orifice (4) by the armature spring (2). The pressure across the diaphragm (5) is built up via the equalizing orifice (7). The diaphragm closes the main orifice (6) as soon as the pressure across the diaphragm is equivalent to the inlet pressure. The valve will be closed for as long as the voltage to the coil is disconnected.

Coil voltage connected (open):

When voltage is applied to the coil (1), the pilot orifice (4) is opened. As the pilot orifice is larger than the equalizing orifice (7), the pressure across the diaphragm (5) drops and therefore it is lifted clear of the main orifice (6). The valve is now open for unimpeded flow and will be open for as long as the minimum differential pressure across the valve is maintained, and for as long as there is voltage to the coil.

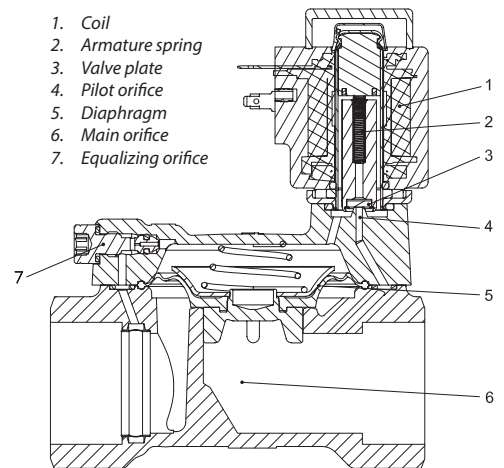

Function
NO, brass, DZR brass and stainless steel

Coil voltage disconnected (open):

When the voltage to the coil (2) is disconnected, the pilot orifice (4) is open. As the pilot orifice is larger than the equalizing orifice (7), the pressure across the diaphragm (5) drops and therefore it is lifted clear of the main orifice (6). The valve will be open for as long as the minimum differential pressure across the valve is maintained, and for as long as the voltage to the coil is disconnected.

Coil voltage connected (closed):

When voltage is applied to the coil, the valve plate (3) is pressed down against the pilot orifice (4). The pressure across the diaphragm (5) is built up via the equalizing orifice (7). The diaphragm closes the main orifice (6) as soon as the pressure across the diaphragm is equivalent to the inlet pressure. The valve will be closed for as long as there is voltage to the coil.

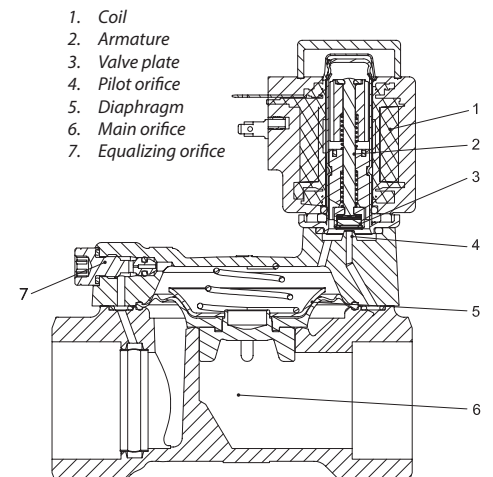

Capacity diagrams:

Example, water:
Capacity for EV220B 15B at differential pressure of 3 bar. Approx. 7 m³/h

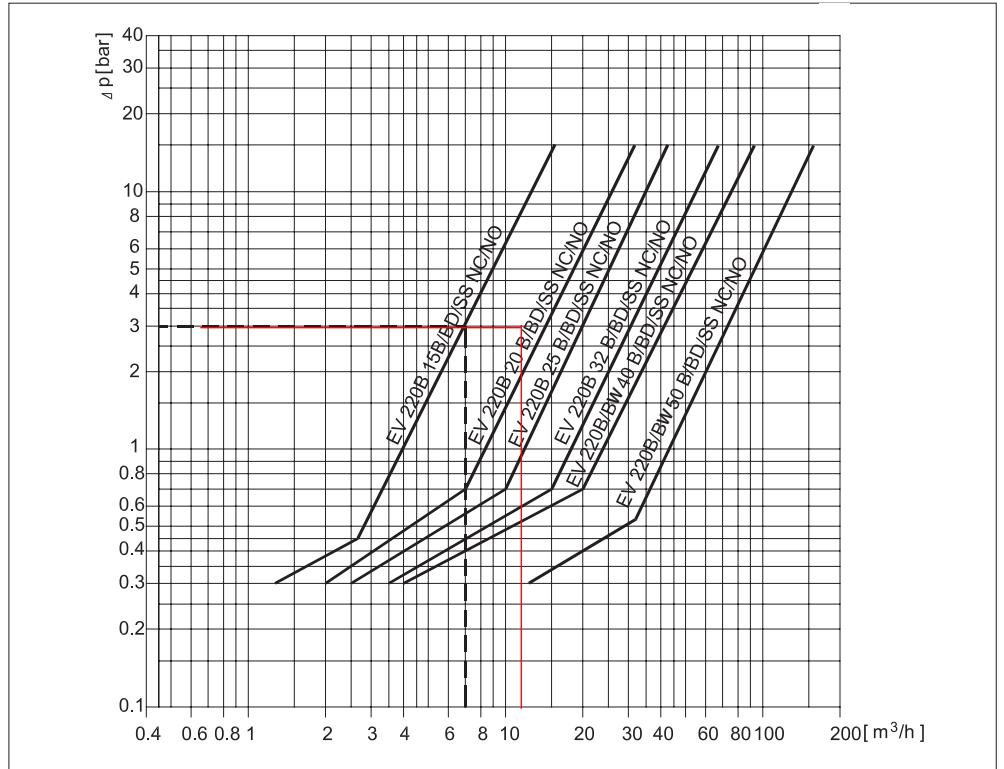

Example, air:
Capacity for EV220B 15B at inlet pressure (p₁) of 5 bar and outlet pressure (p₂) of 3.5 bar. Approx. 245 Nm³/h

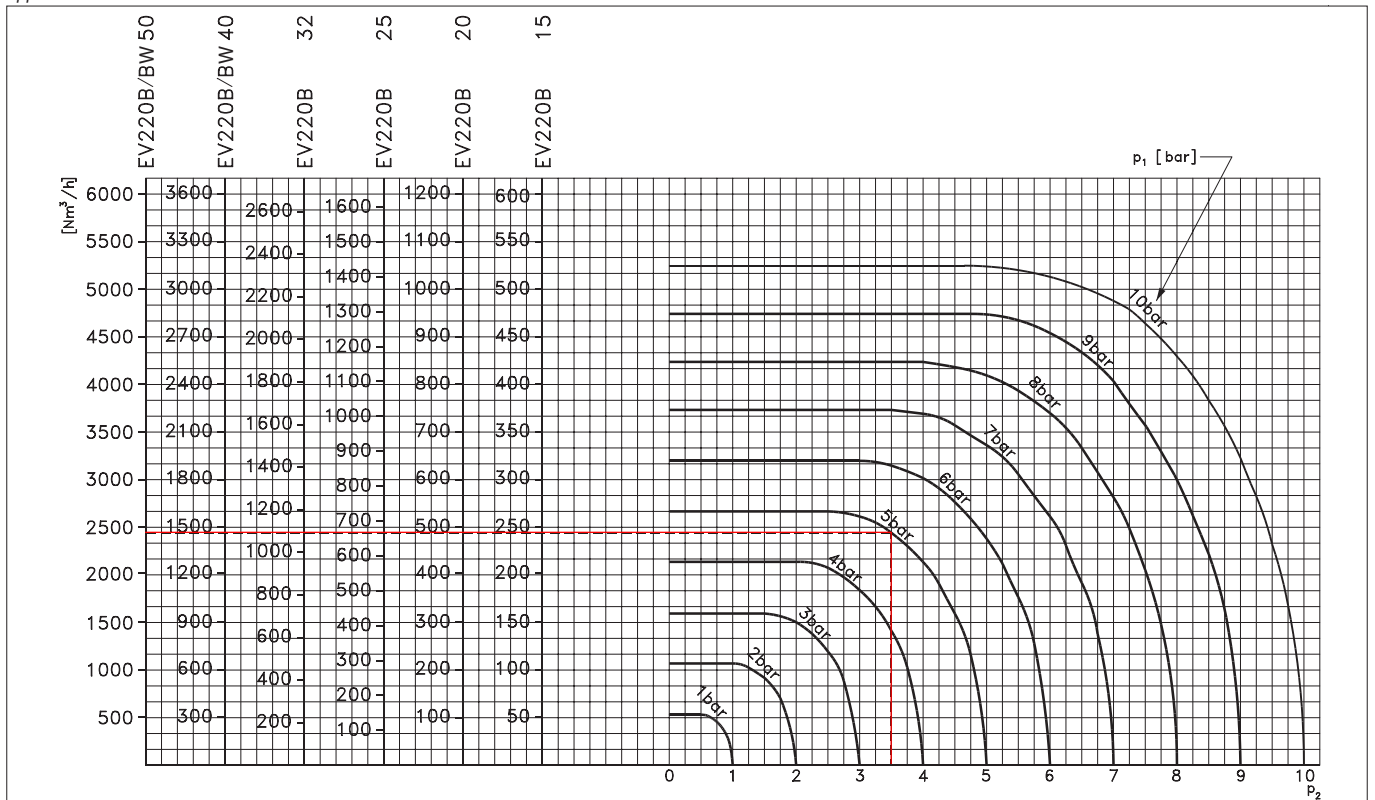

Danfoss can accept no responsibility for possible errors in catalogues, brochures and other printed material. Danfoss reserves the right to alter its products without notice. This also applies to products already on order provided that such alterations can be made without consequential changes being necessary in specifications already agreed. All trademarks in this material are property of the respective companies. Danfoss and the Danfoss logotype are trademarks of Danfoss A/S. All rights reserved.